

Arjan Coffee Table





ASSEMBLY INSTRUCTIONS

JOON LOLOI

ASSEMBLY INSTRUCTIONS: BEFORE BEGINNING

Read these instructions carefully and keep for future reference. Refer to parts inventory for guidance, and ensure you have all pieces before starting. When assembling, place all parts on a soft, clean, and flat surface such as a carpet to prevent scratches.

1. Carefully unpack and position the item on a clean, non-marring surface to assemble.
2. Read these Assembly Instructions from beginning to end before starting to assemble.
3. Take an inventory of the required parts to ensure all are available.
4. To prevent accidental choking hazards, keep all packing materials away from small children.
5. Only tighten hardware until ALL hardware are fully engaged on their locations. Over tighten bolts will damage the bolt threads.
6. Use only factory provided hardware to assemble. Unapproved hardware can damage product or jeopardize the structural integrity of the product.
7. The use of power tool to assemble is not recommended due to high risk of over-torque, which can damage the product.

HARDWARE INVENTORY				
ID	IMAGE	DESCRIPTION	SIZE	QTY
A		ALLEN BOLT	M6 x 12mm	4
B		ALLEN WRENCH	M4 x 110mm	1
C		TOP		1
D		BASE		1

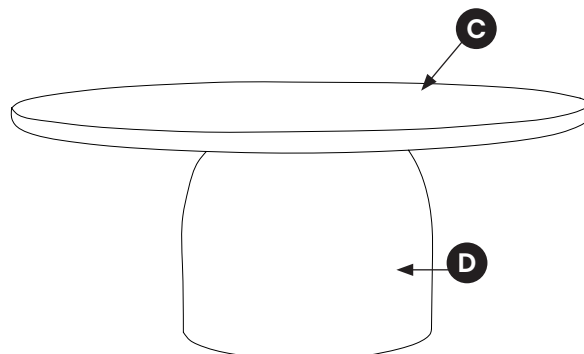

JOON LOLOI

STEP 1

Place the TOP (C) flat on the ground with the bottom side that attached to the BASE (D) upward. Place the connecting plate on the BASE (D) on top of the table TOP (C) matching up the holes the BOLTS (A) will go through to secure the BASE (D) and TOP (C) together.

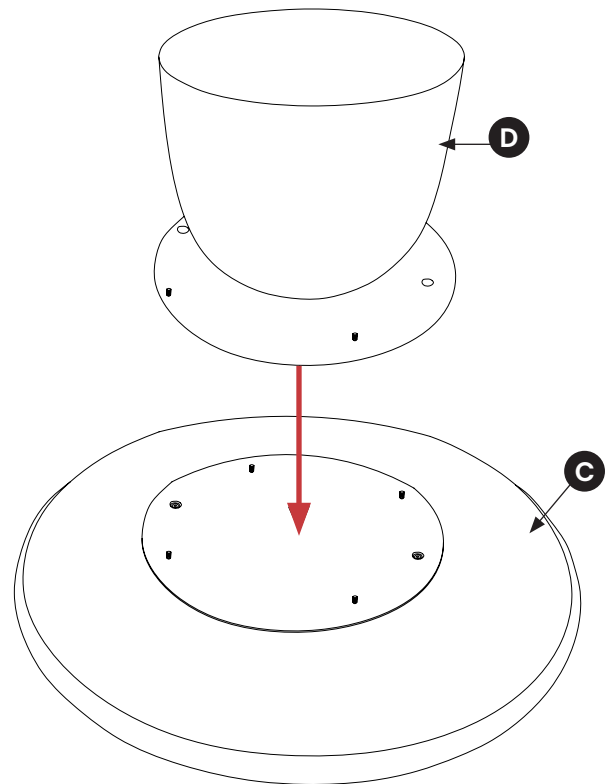

STEP 2

Slide the ALLEN BOLT (A) through each hole and tighten with ALLEN WRENCH (B). Do this securely, but make sure it's not too tight as to damage the bolt or furniture. Once all ALLEN BOLTS (A) are screwed in and secured the assembly is complete.

