

Buchanan Coffee Table



ASSEMBLY INSTRUCTIONS

JOON LOLOI

ASSEMBLY INSTRUCTIONS: BEFORE BEGINNING

Read these instructions carefully and keep for future reference. Refer to parts inventory for guidance, and ensure you have all pieces before starting. When assembling, place all parts on a soft, clean, and flat surface such as a carpet to prevent scratches.

PARTS INVENTORY		
ID	DESCRIPTION	QTY
1	TOP	1
2	LEGS	4

HARDWARE INVENTORY				
ID	IMAGE	DESCRIPTION	SIZE	QTY
A		ALLEN BOLT	M6 x 16mm	16
B		FLAT WASHER	16 x 8mm	16
C		ALLEN WRENCH	4mm	1

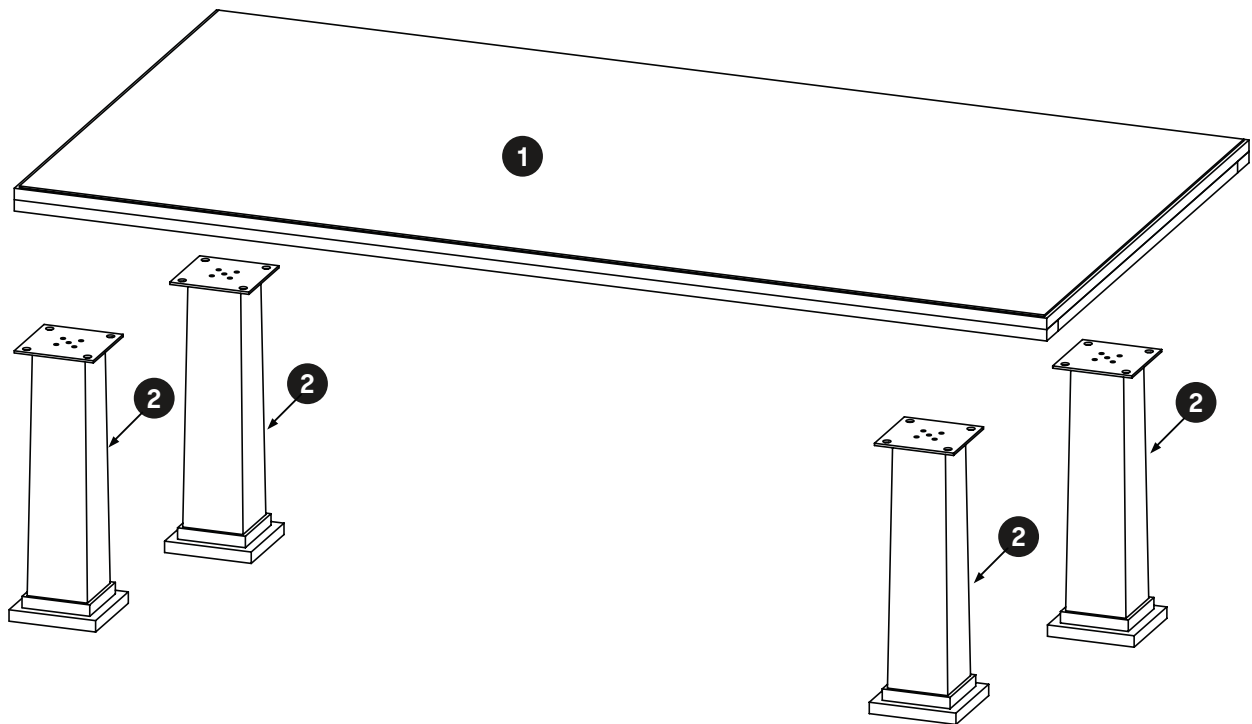

JOON LOLOI

STEP 1

Turn the **Top (1)** upside down and place the **Legs (2)** on top, ensuring bolt holes are aligned with the metal plates.

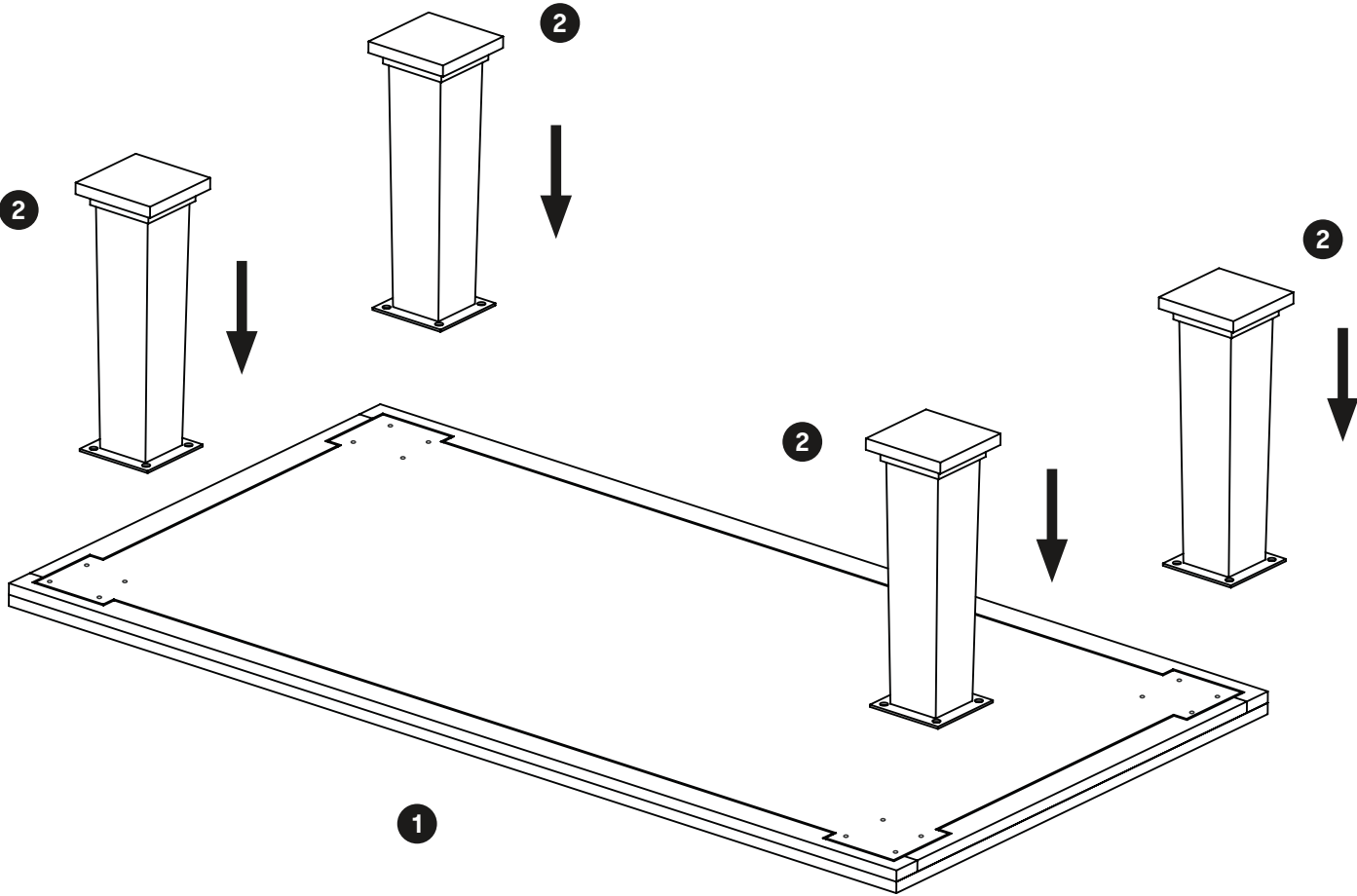

JOON LOLOI

STEP 2

Slide **Washer (B)** onto **Allen Bolt (A)**. Align the bolt hole on the **Legs (2)** with the **Top (1)** and attach them using **Allen Wrench (C)**. Repeat this process for all bolts.

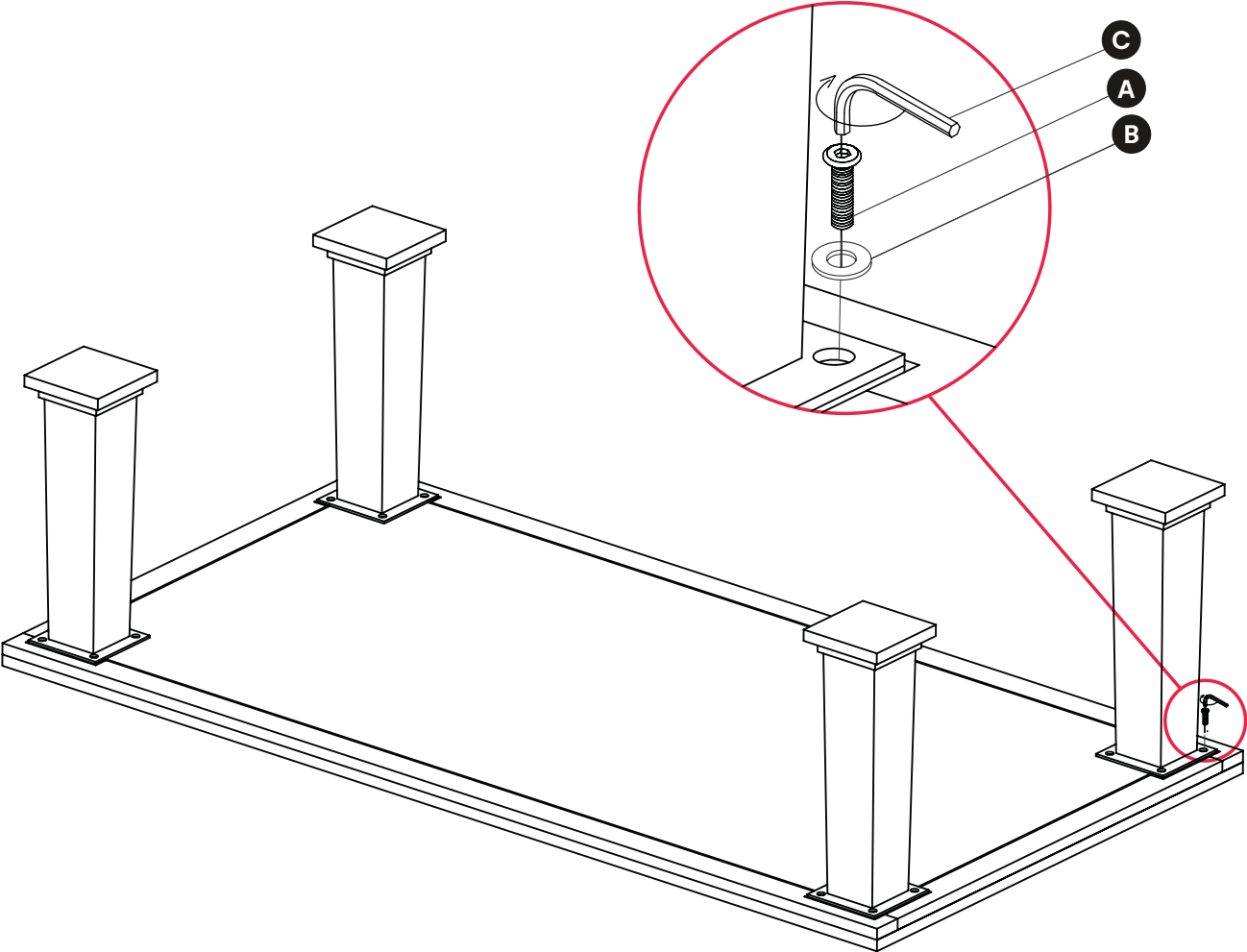

JOON LOLOI

STEP 3

Turn the coffee table right side up after tightening all the bolts.

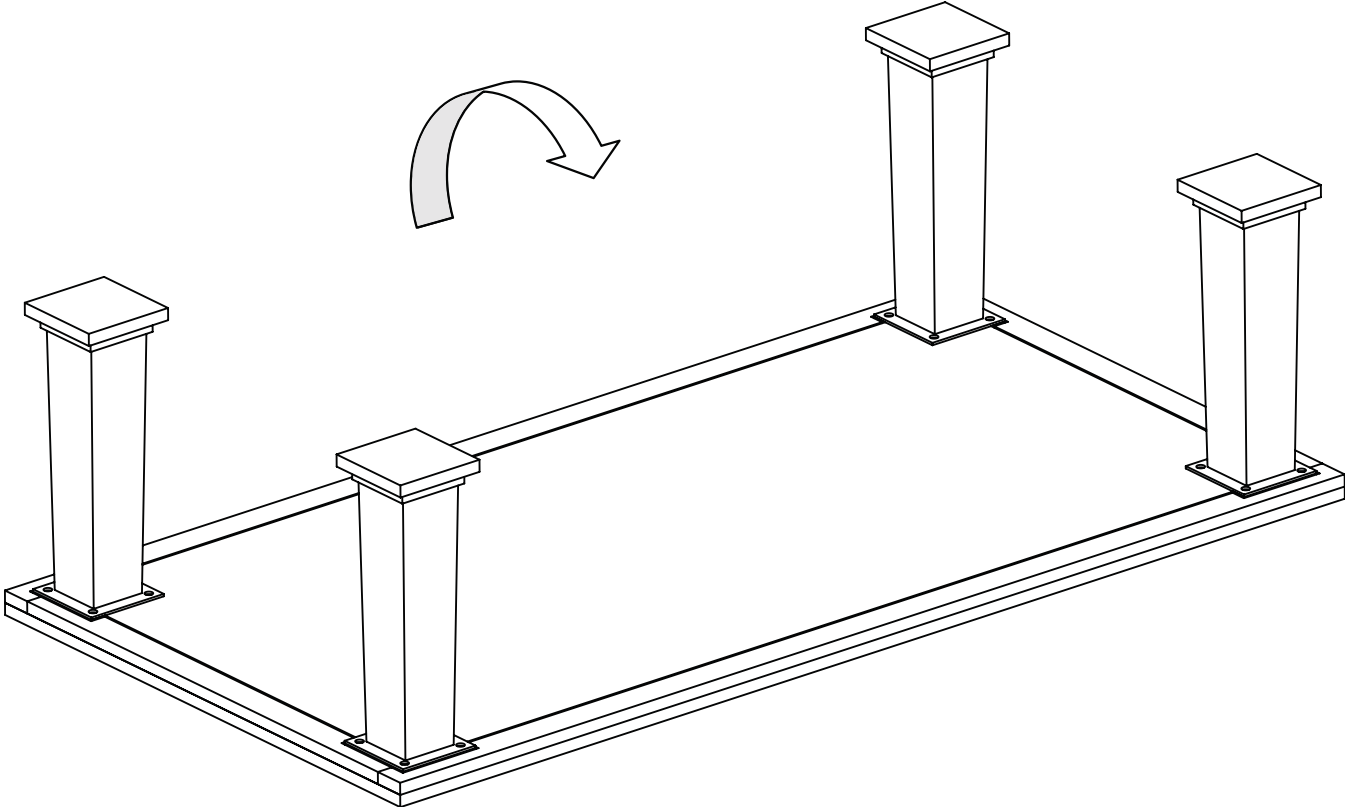

JOON LOLOI

STEP 4

Once all components have been secured, the assembly is complete.

