

# Dearborn Travertine End Table

---





## ASSEMBLY INSTRUCTIONS

# JOON LOLOI

## ASSEMBLY INSTRUCTIONS: BEFORE BEGINNING

Read these instructions carefully and keep for future reference. Refer to parts inventory for guidance, and ensure you have all pieces before starting. When assembling, place all parts on a soft, clean, and flat surface such as a carpet to prevent scratches.

| PARTS INVENTORY |                |     |
|-----------------|----------------|-----|
| ID              | DESCRIPTION    | QTY |
| 1               | TOP            | 1   |
| 2               | MOUNTING PANEL | 1   |
| 3               | POST           | 1   |
| 4               | BASE           | 1   |

| HARDWARE INVENTORY |   |              |           |     |
|--------------------|---|--------------|-----------|-----|
| ID                 | IMAGE   | DESCRIPTION  | SIZE      | QTY |
| A                  |    | TAP BOLT     | M8 x 20mm | 7   |
| B                  |    | ALLEN BOLT   | M8 x 50mm | 2   |
| C                  |    | LOCK WASHER  | 14 x 9mm  | 2   |
| D                  |   | FLAT WASHER  | 19 x 9mm  | 2   |
| E                  |  | ALLEN WRENCH | 5mm       | 1   |

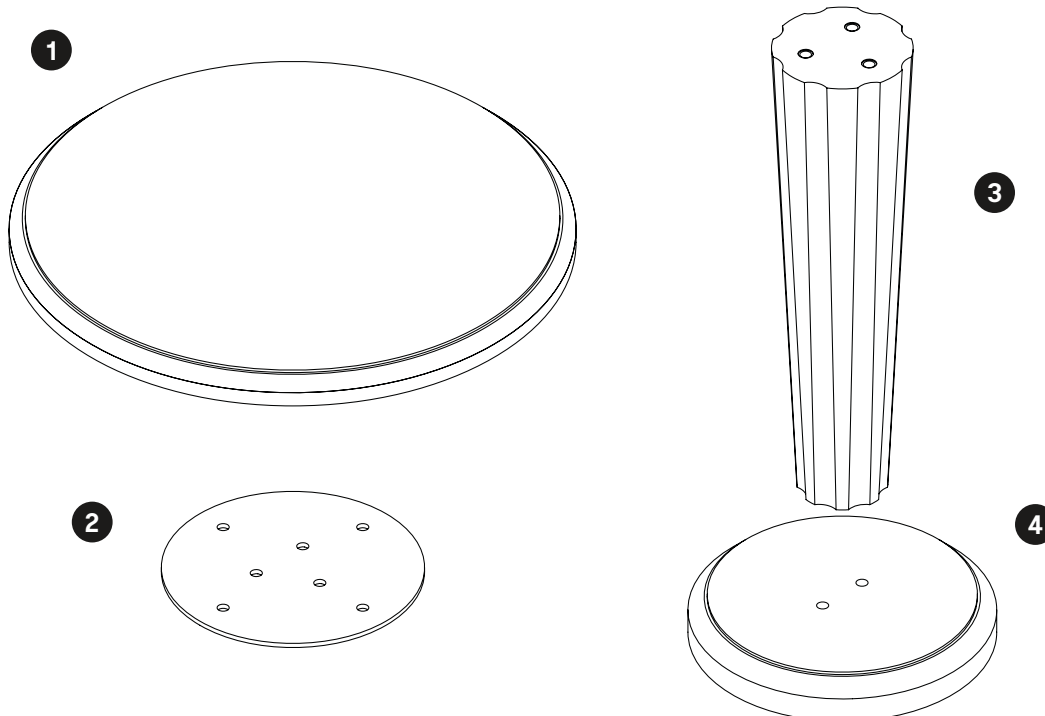

# JOON LOLOI

---

## STEP 1

Place the **Post (3)** on its TOP so that the bottom can be easily accessed. Slide the **Lock Washer (C)** and the **Flat Washer (D)** onto the **Allen Bolt (B)**. Match up the bolt holes on the bottom of the **Base (4)** and attach to the bottom of the **Post (3)** using the **Allen Wrench (E)**, to screw in the **Allen Bolt (B)**. Do this for both bolts.

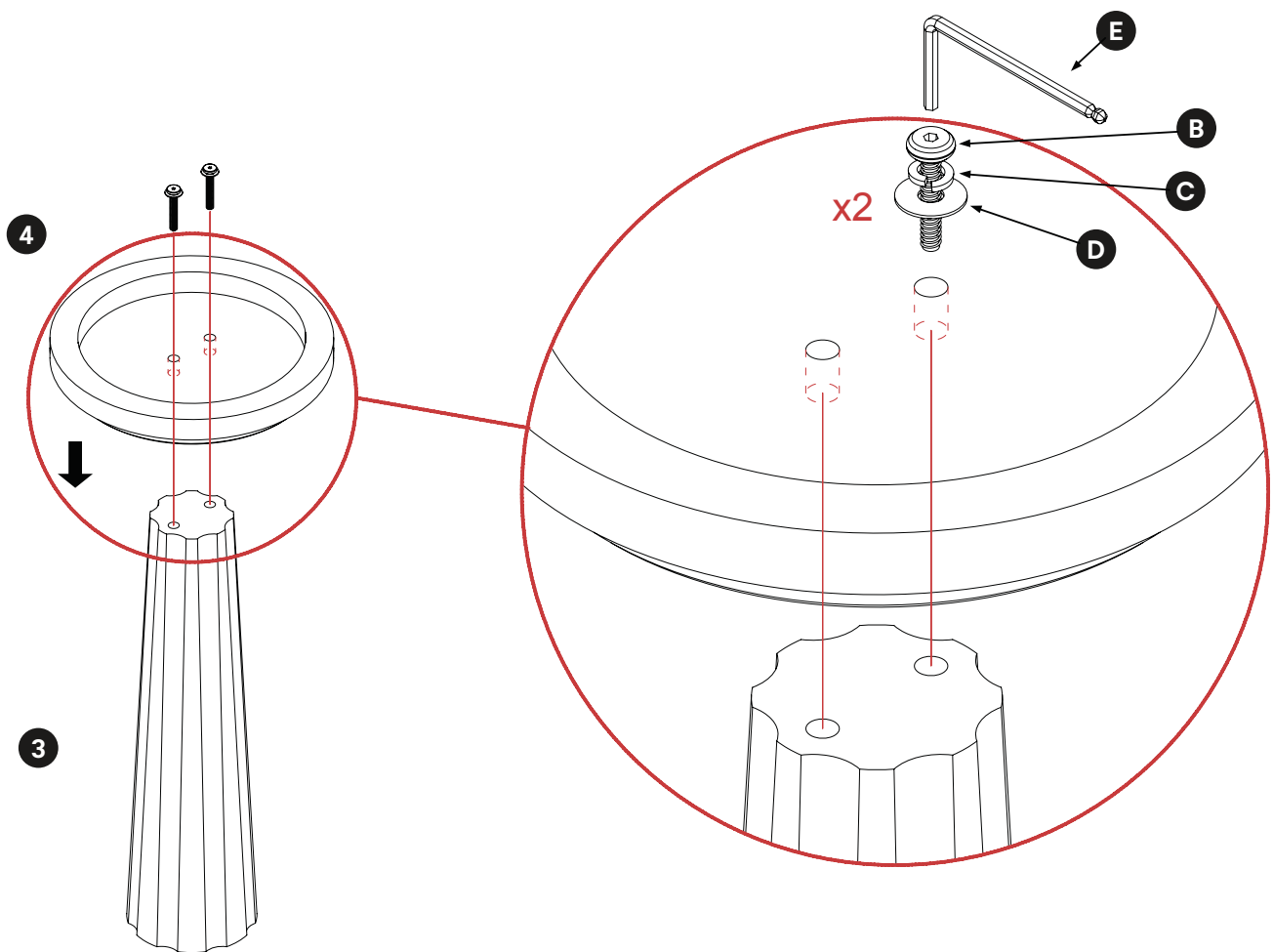

# JOON LOLOI

## STEP 2

Place the combined **Post (3)** and **Base (4)** on its bottom. Match up the bolt holes on the bottom of the **Mounting Panel (2)** and attach to the **Post (3)** using **Allen Wrench (E)** to screw in the **Tap Bolt (A)**. Do this for all three bolts.

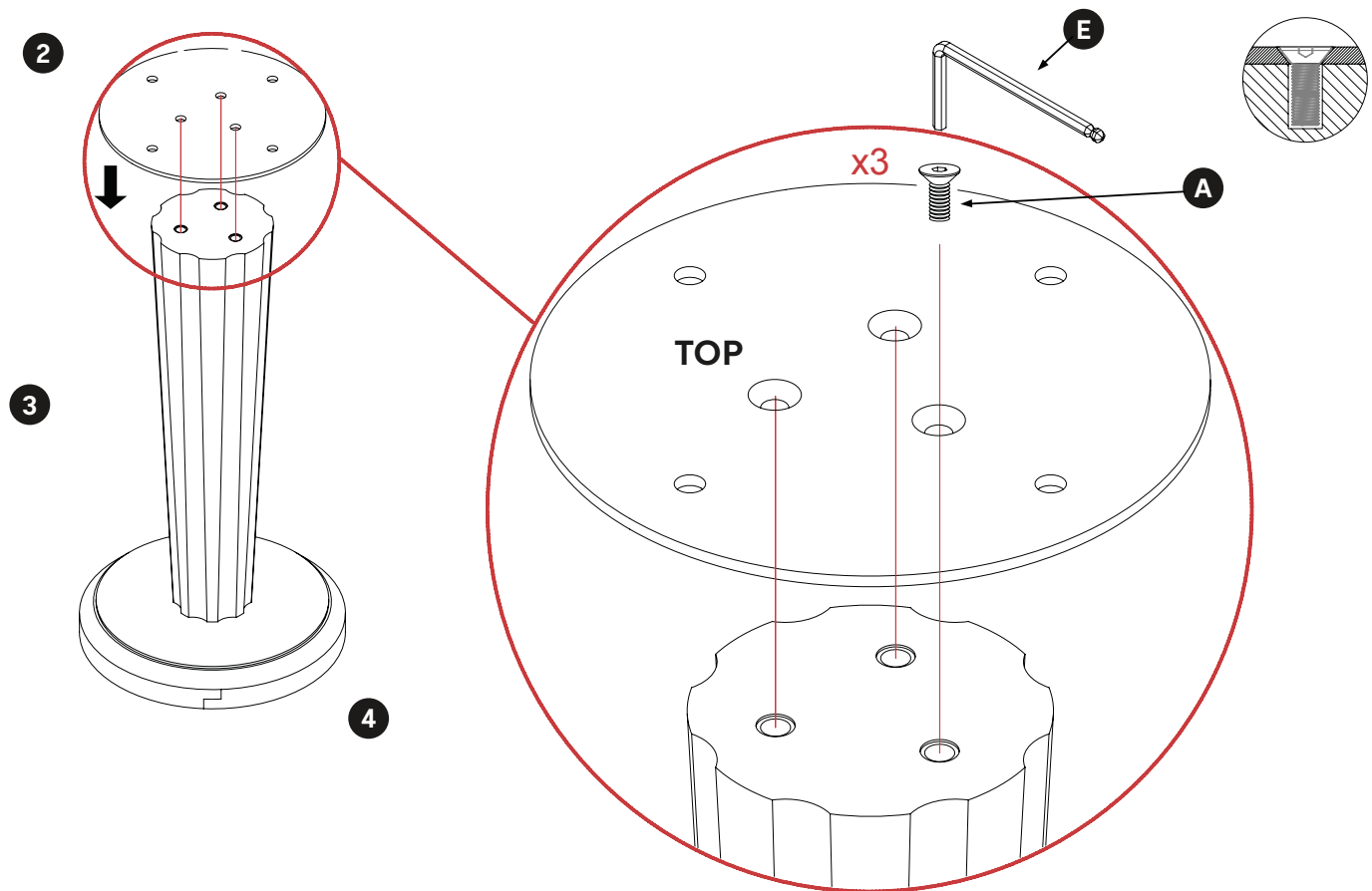

# JOON LOLOI

## STEP 3

Place the **Top (1)** on its top. Match up the bolt holes on the bottom of the **Mounting Panel (2)** and attach to the bottom of the **Top (1)** using **Allen Wrench (E)** to screw in the **Tap Bolt (A)**. Do this for all four bolts.

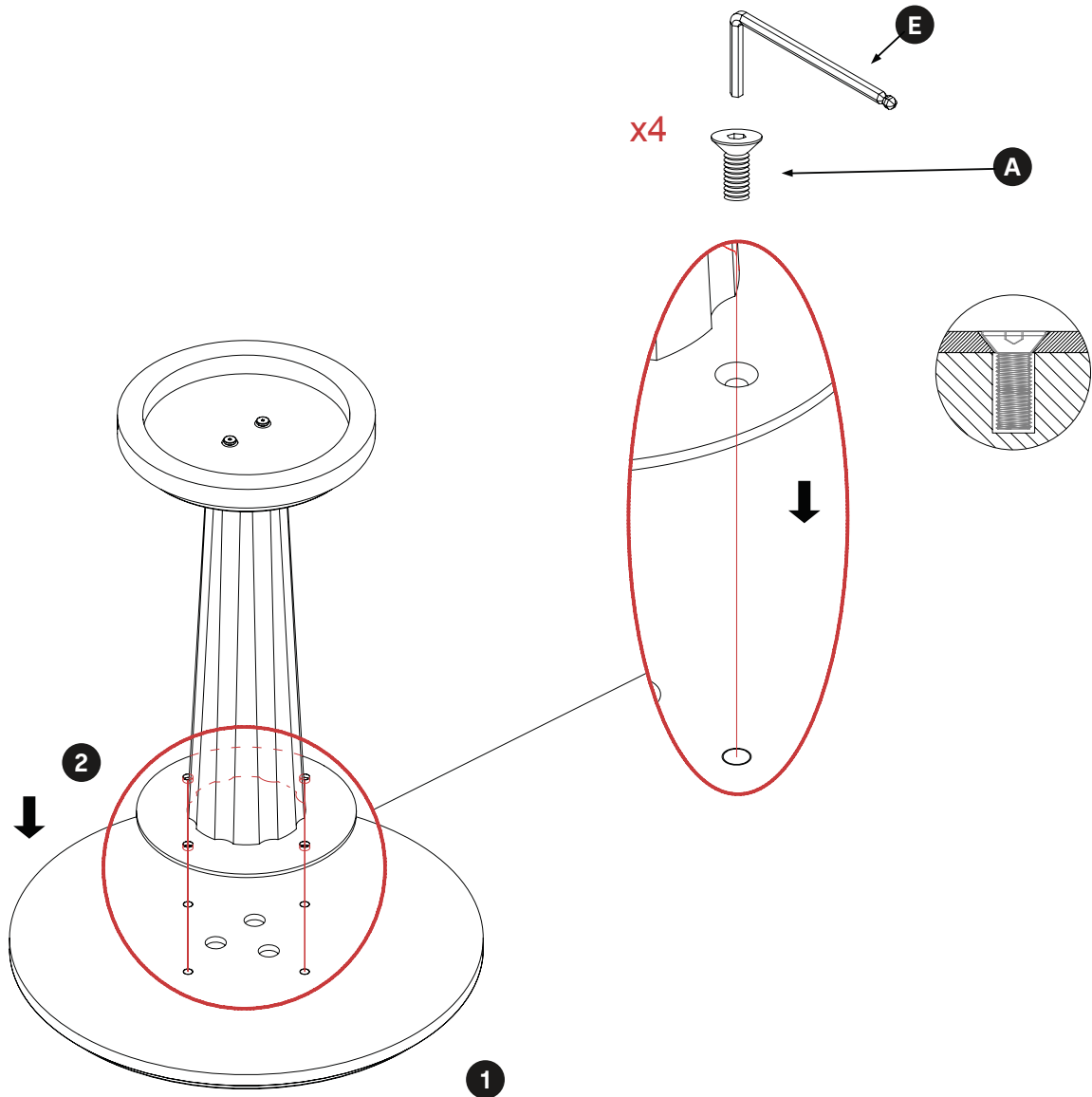

# JOON LOLOI

---

## STEP 4

Once all components have been secured, assembly is complete.

