

Halsted Coffee Table





ASSEMBLY INSTRUCTIONS

JOON LOLOI

ASSEMBLY INSTRUCTIONS

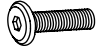
Read these instructions carefully and keep for future reference. Refer to parts inventory for guidance, and ensure you have all pieces before starting. When assembling, place all parts on a soft, clean, and flat surface such as a carpet to prevent scratches.

PARTS INVENTORY		
ID	DESCRIPTION	QTY
1	TABLE TOP	1
2	TABLE LEGS	2
3	SUPPORTS TIE BAR	2

HARDWARE INVENTORY				
ID	IMAGE	DESCRIPTION	SIZE	QTY
A		ALLEN BOLT	M6 x 20mm	16
B		ALLEN BOLT	M6 x 45mm	4
C		FLAT WASHER	6 x 17mm	20
D		LOCK WASHER	6 x 13mm	20
E		ALLEN WRENCH	4mm	1

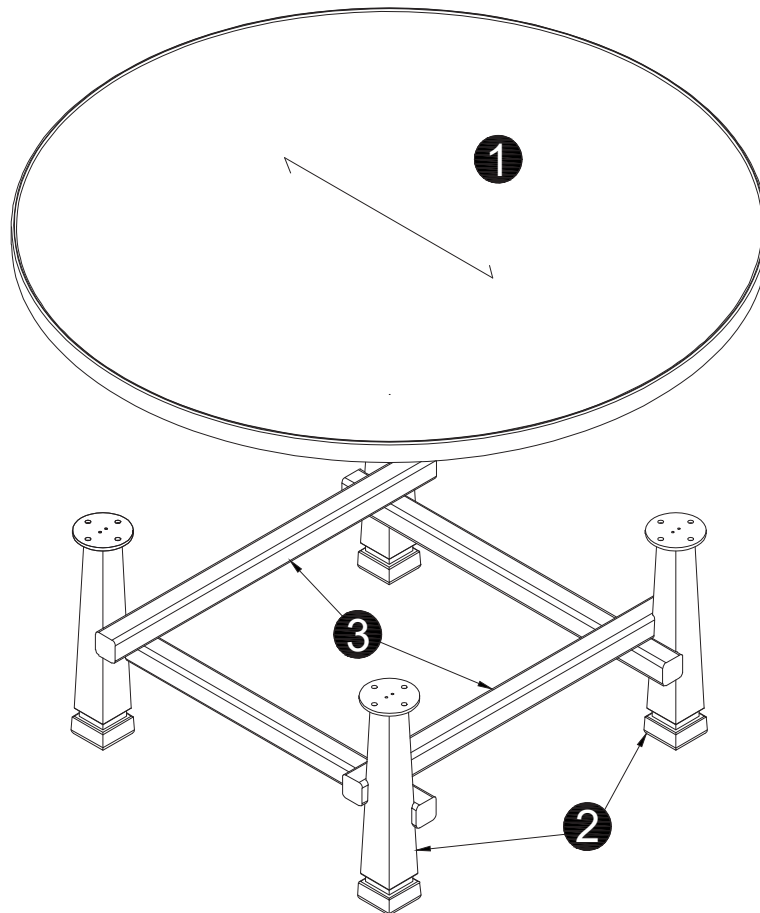

JOON LOLOI

STEP 1

Place piece 1 on it's back so that the bottom can be easily accessed. Slide **LOCK WASHER (D)**, and **FLAT WASHER (C)** onto **ALLEN BOLT (A)**. Match up the bolt holes on the left leg and attach to the bottom of the table using **ALLEN WRENCH (E)**, to screw in **ALLEN BOLT (A)**. Do this for all four bolts.

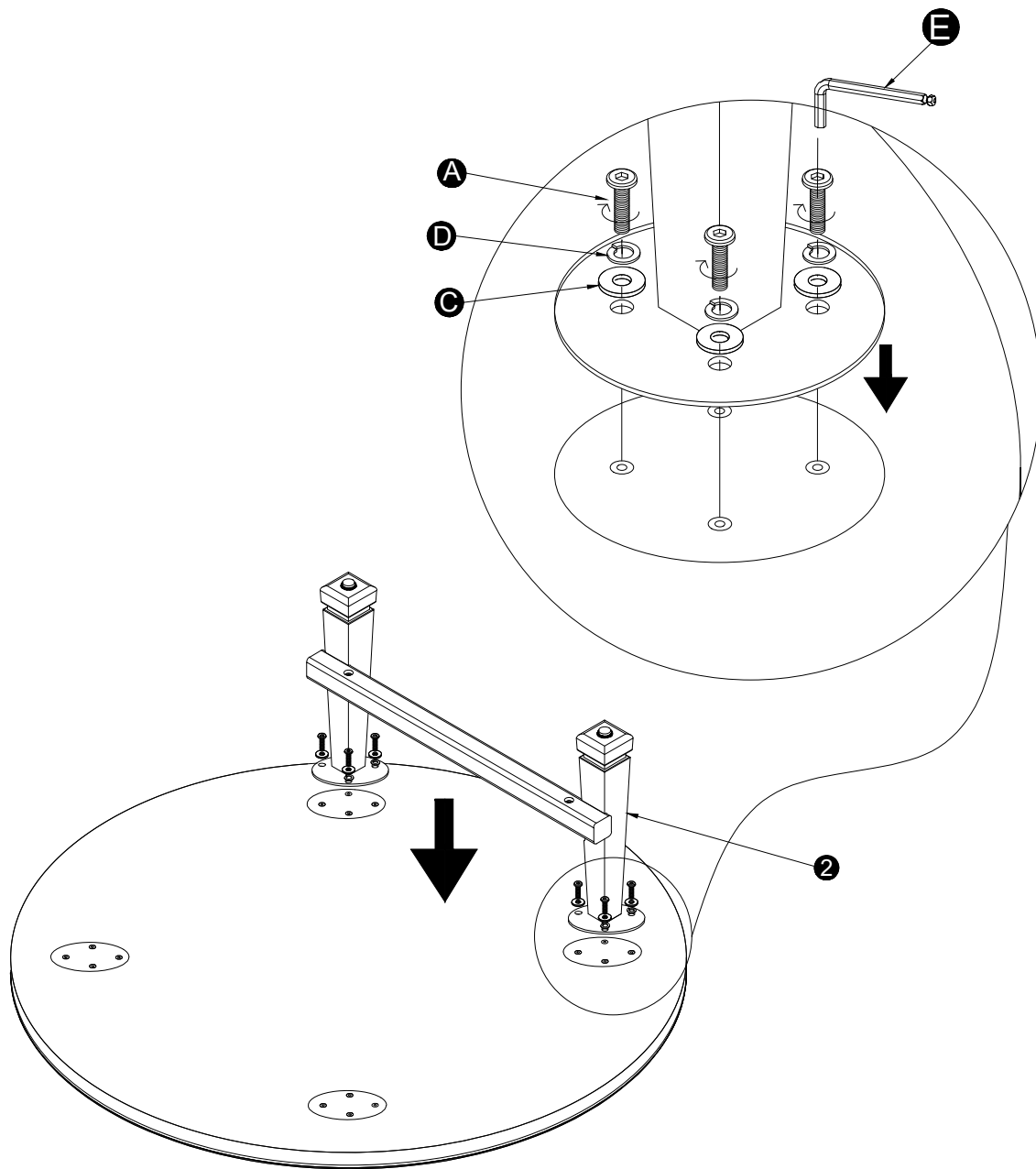

JOON LOLOI

STEP 2

Repeat STEP 1 to attach the right leg. Slide **LOCK WASHER (D)** and then **FLAT WASHER (C)** onto **ALLEN BOLT (A)**. Match up the bolt holes on the left leg and attach to the bottom of the table using **ALLEN WRENCH (E)** to screw in **ALLEN BOLT (A)**. Do this for all four bolts.

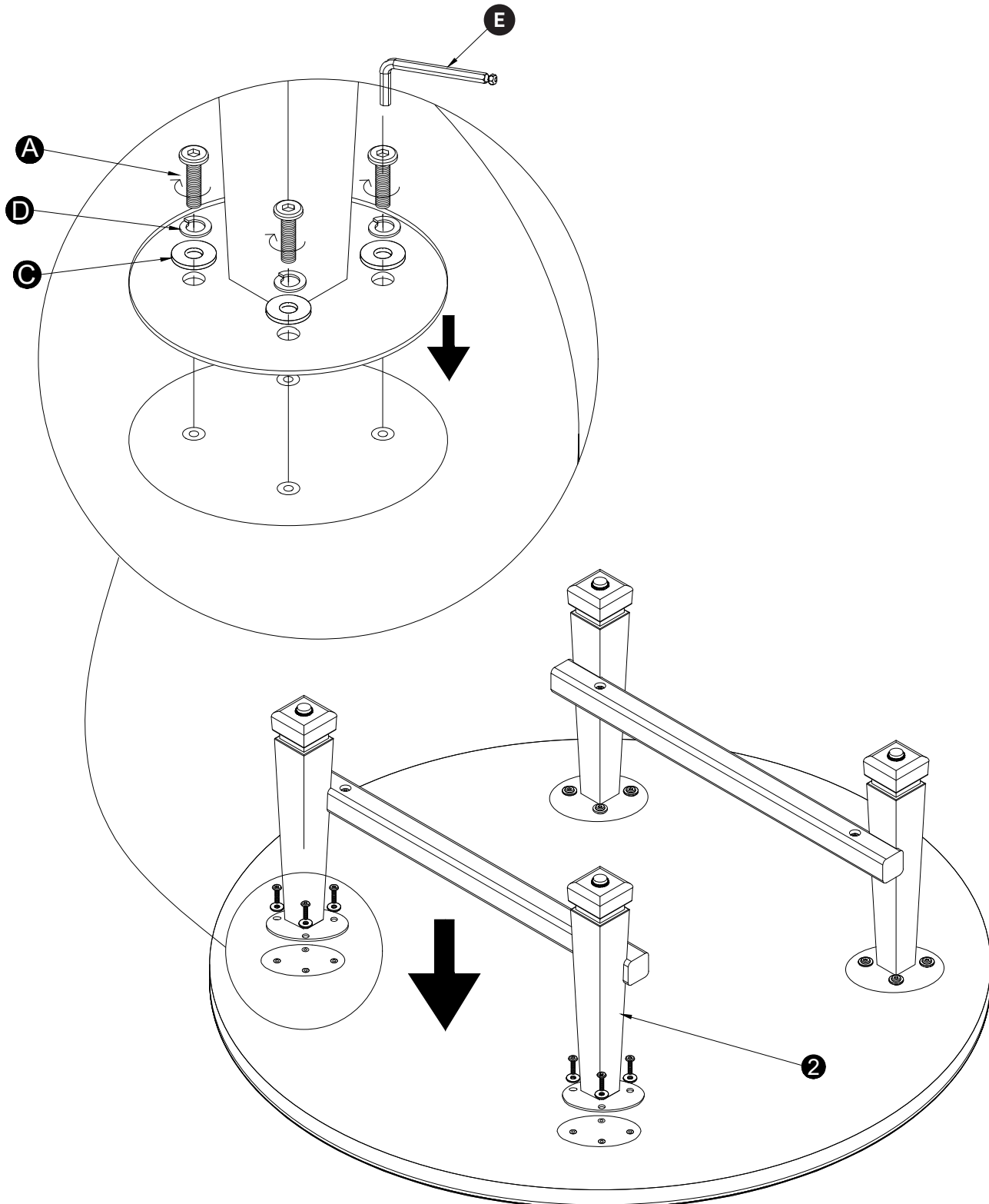

JOON LOLOI

STEP 3

Next, attach the two supports tie bars. Slide **LOCK WASHER (D)**, and then **FLAT WASHER (C)** onto **ALLEN BOLT (B)**. Match up the bolt holes on the left leg and right leg attach to the bottom of the supports tie bar using **ALLEN WRENCH (E)** to screw in **ALLEN BOLT (B)**. Do this for all four bolts.

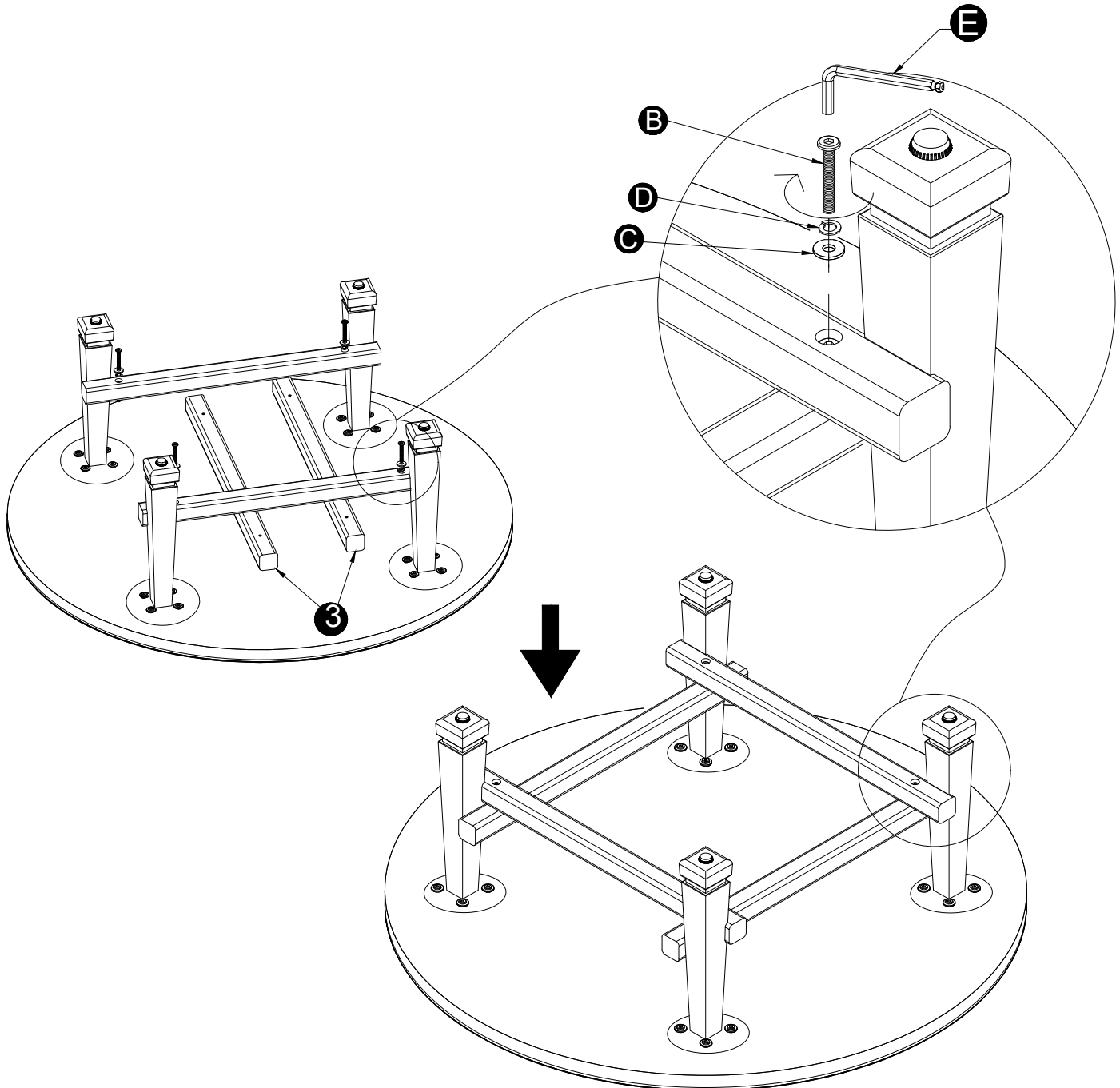

JOON LOLOI

STEP 4

All four legs on the Halsted Coffee Table have the ability to move up and down by twisting left or right. This allows the user to make the table level. Adjust levelers as needed.

