





Paxton End Table

ASSEMBLY INSTRUCTIONS

ASSEMBLY INSTRUCTIONS: BEFORE BEGINNING

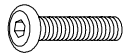
Read these instructions carefully and keep for future reference. Refer to parts inventory for guidance, and ensure you have all pieces before starting. When assembling, place all parts on a soft, clean, and flat surface such as a carpet to prevent scratches.

1. Carefully unpack and position the item on a clean, non-marring surface to assemble.
2. Read these Assembly Instructions from beginning to end before starting to assemble.
3. Take an inventory of the required parts to ensure all are available.
4. To prevent accidental choking hazards, keep all packing materials away from small children.
5. Only tighten hardware until ALL hardware are fully engaged on their locations. Over-tighten bolts will damage the bolt threads.
6. Use only factory provided hardware to assemble. Unapproved hardware can damage product or jeopardize the structural integrity of the product.
7. The use of power tool to assemble is not recommended due to high risk of over-torque, which can damage the product.

| HARDWARE INVENTORY | | | | |
|--------------------|---|---------------|--------|-----|
| ID | IMAGE | DESCRIPTION | SIZE | QTY |
| A |  | ALLEN BOLT | 8x20mm | 6 |
| B |  | ALLEN WRENCH | 4 mm | 1 |
| C |  | SPRING WASHER | 8x19mm | 6 |
| D |  | WASHER | 8x19mm | 6 |

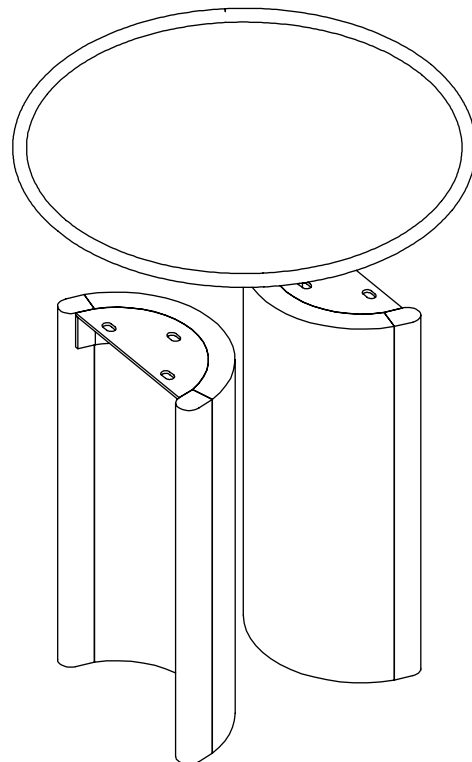

JOON LOLOI

STEP 1

Place the table top on the ground with the bottom facing upward. Then place each leg in its corresponding place. The rounded edge of the legs facing inward. Screw in the legs by using the ALLEN WRENCH (B) threading the BOLT (A) sliding the WASHER (D), and then SPRING WASHER (C) onto the BOLT (A) and then through the holes of the legs and desk top. Do this for both legs.

ALIGN LEGS WITH FRAME
BEFORE TIGHTENING

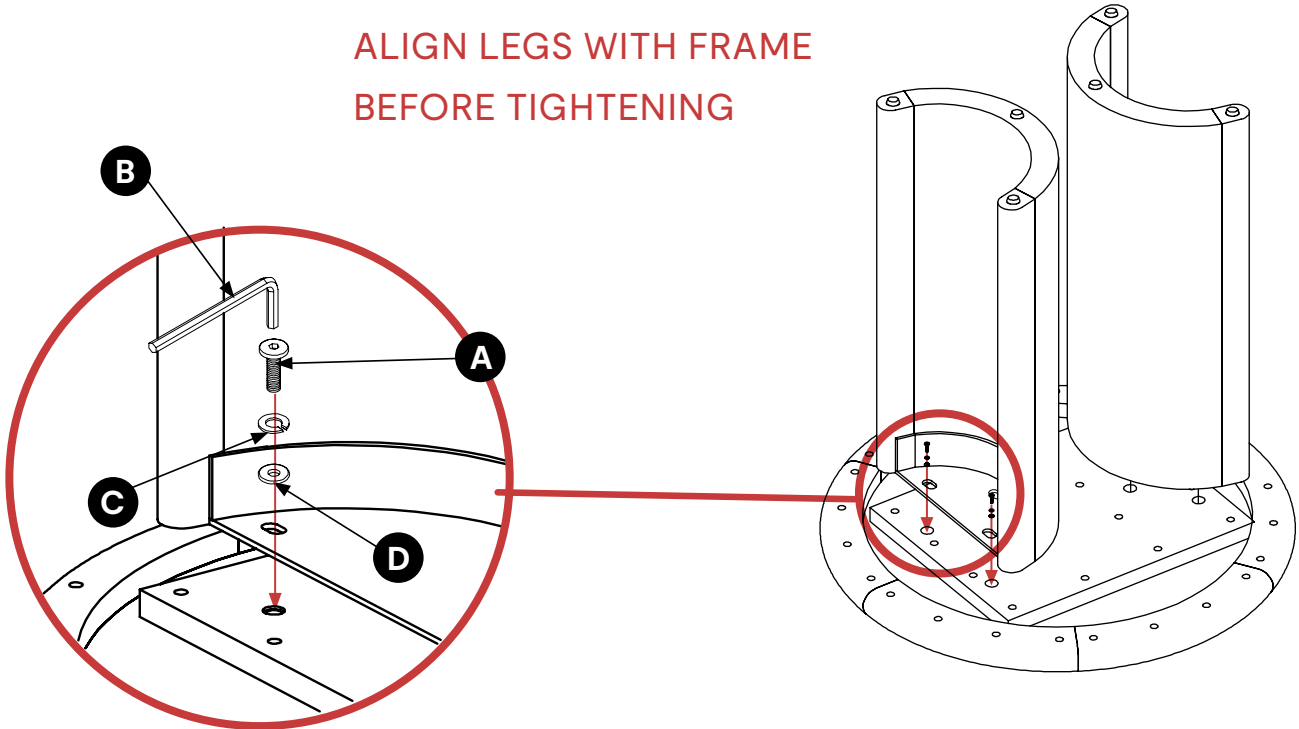

STEP 2

To make sure the table is level, you can adjust the feet on the bottom of the legs by rotating them higher or lower.

