

# Quincy Dining Table

---





## ASSEMBLY INSTRUCTIONS

# JOON LOLOI

## ASSEMBLY INSTRUCTIONS: BEFORE BEGINNING

Read these instructions carefully and keep for future reference. Refer to parts inventory for guidance, and ensure you have all pieces before starting. When assembling, place all parts on a soft, clean, and flat surface such as a carpet to prevent scratches.

PARTS INVENTORY		
ID	DESCRIPTION	QTY
<b>1</b>	TOP	1
<b>2</b>	BASE	1

HARDWARE INVENTORY				
ID	IMAGE	DESCRIPTION	SIZE	QTY
<b>A</b>		ALLEN BOLT	M8 x 35mm	4
<b>B</b>		LOCK WASHER	12 x 9mm	4
<b>C</b>		FLAT WASHER	19 x 9mm	4
<b>D</b>		ALLEN WRENCH	5mm	1
<b>E</b>		LEVELING GLIDE	M8 x 25mm	6

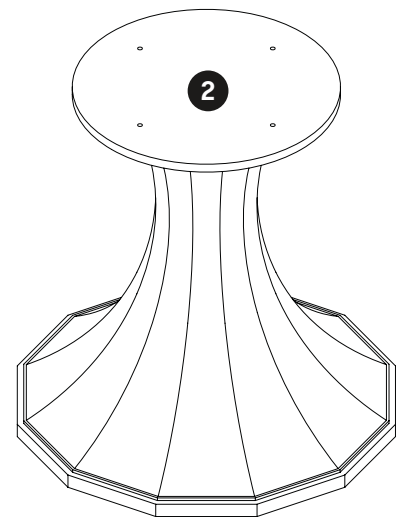
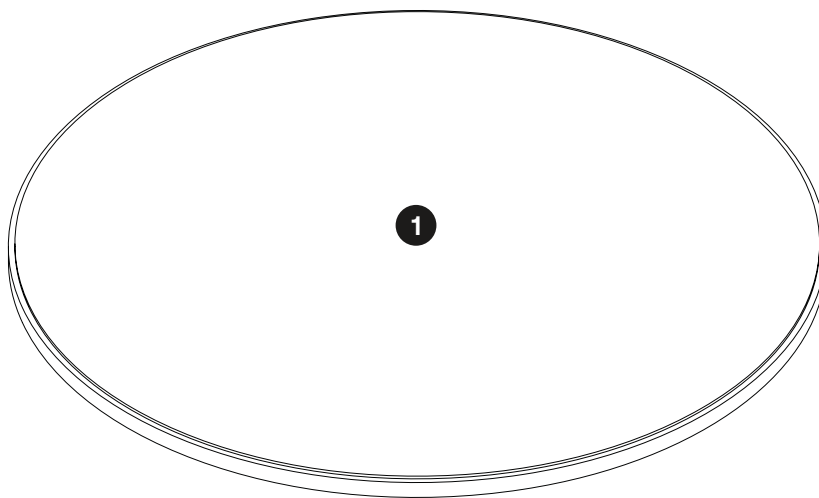

# JOON LOLOI

---

## STEP 1

Place the **TOP (1)** onto the **BASE (2)**, making sure the bolt holes are aligned. Slide the **LOCK WASHER (B)** and then the flat **WASHER (C)** onto the **ALLEN BOLT (A)**. Ensure the bolt holes on the **BASE (2)** match up with the **TOP (1)** and attach using the **ALLEN WRENCH (D)**, to screw in the **ALLEN BOLT (A)**. Repeat this for all remaining bolts.

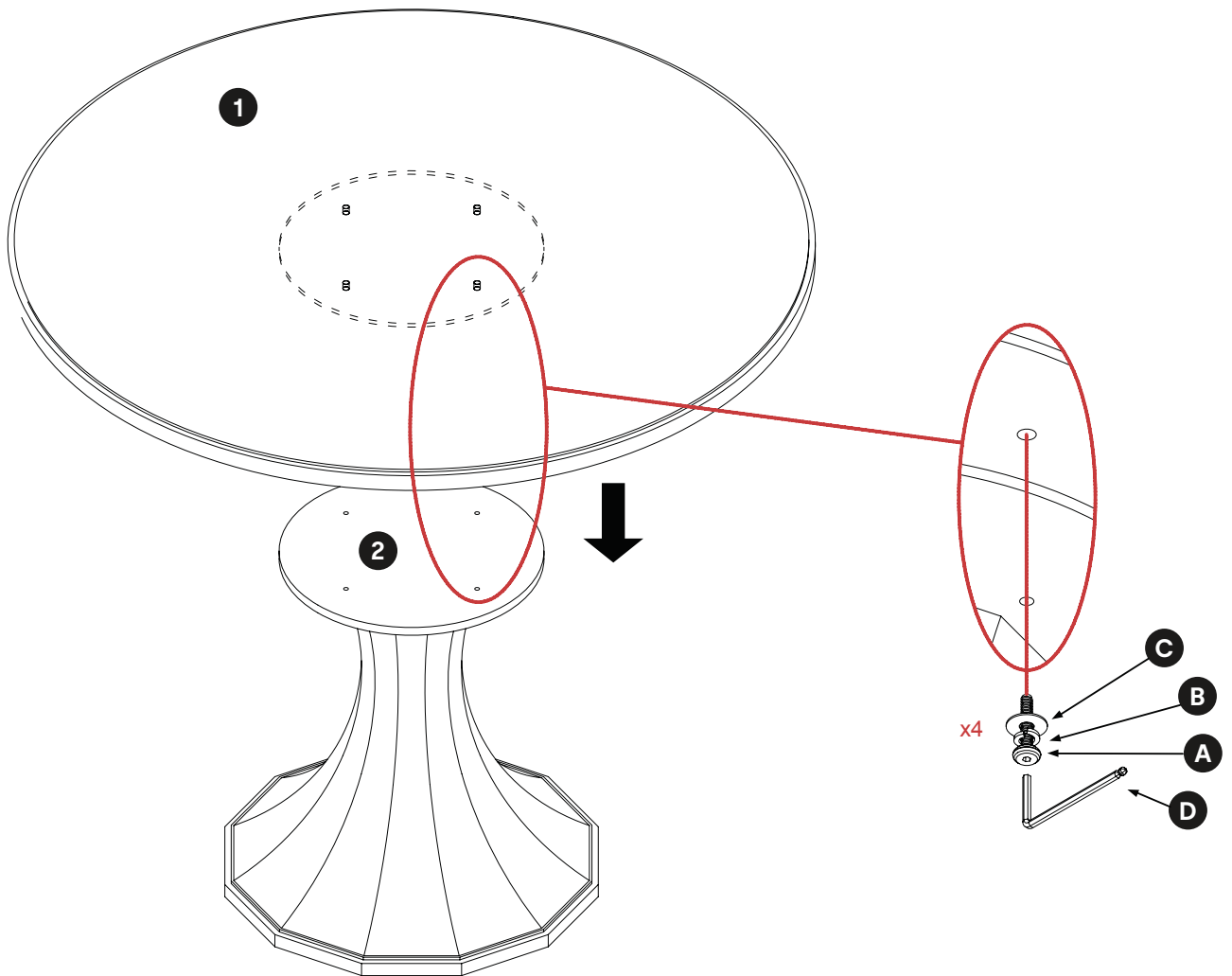

# JOON LOLOI

---

## STEP 2

The **LEVELING GLIDE (E)** is located at the bottom of the **BASE (2)**, so when you place the furniture in the right position, you can adjust the **LEVELING GLIDES (E)** depending on the surface. Make sure it is level and stable. Once your table is level, the assembly is complete.

