

Richmond End Table





ASSEMBLY INSTRUCTIONS



JOON LOLOI

ASSEMBLY INSTRUCTIONS: BEFORE BEGINNING

Read these instructions carefully and keep for future reference. Refer to parts inventory for guidance, and ensure you have all pieces before starting. When assembling, place all parts on a soft, clean, and flat surface such as a carpet to prevent scratches.

1. Carefully unpack and position the item on a clean, non-marring surface to assemble.
2. Read these Assembly Instructions from beginning to end before starting to assemble.
3. Take an inventory of the required parts to ensure all are available.
4. To prevent accidental choking hazards, keep all packing materials away from small children.
5. Only tighten hardware until ALL hardware are fully engaged on their locations. Over-tighten bolts will damage the bolt threads.
6. Use only factory provided hardware to assemble. Unapproved hardware can damage product or jeopardize the structural integrity of the product.
7. The use of power tool to assemble is not recommended due to high risk of over-torque, which can damage the product.

| HARDWARE INVENTORY | | | | |
|--------------------|---|---------------|-----------|-----|
| ID | IMAGE | DESCRIPTION | SIZE | QTY |
| A |  | ALLEN BOLT | M6 x 30mm | 12 |
| B |  | ALLEN WRENCH | M4 | 1 |
| C |  | SPRING WASHER | M6 x 13mm | 12 |
| D |  | WASHER | M6 x 17mm | 12 |

| FURNITURE INVENTORY | | | |
|---------------------|---|-------------|-----|
| ID | IMAGE | DESCRIPTION | QTY |
| E |  | TOP | 1 |
| F |  | BASE | 1 |

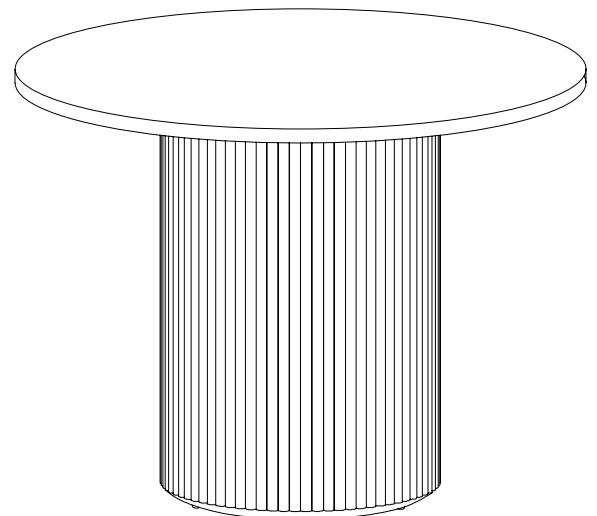

JOON LOLOI

STEP 1

Flip the TOP (E) over so the bottom is exposed and lay on a level clean surface. Place each BASE (F) on either end of the TOP (E) making sure to line up the corresponding holes to secure the TOP (E) and BASE (F) together. Next, put the SPRING WASHER (C) then the WASHER (D) on the BOLT (A) and thread it through the hole. Tighten each bolt with the ALLEN WRENCH (B). Do this eight times until all BOLTS (A), SPRING WASHERS (C), and WASHERS (D) are used and the BASES (F) are secured to the TOP (E).

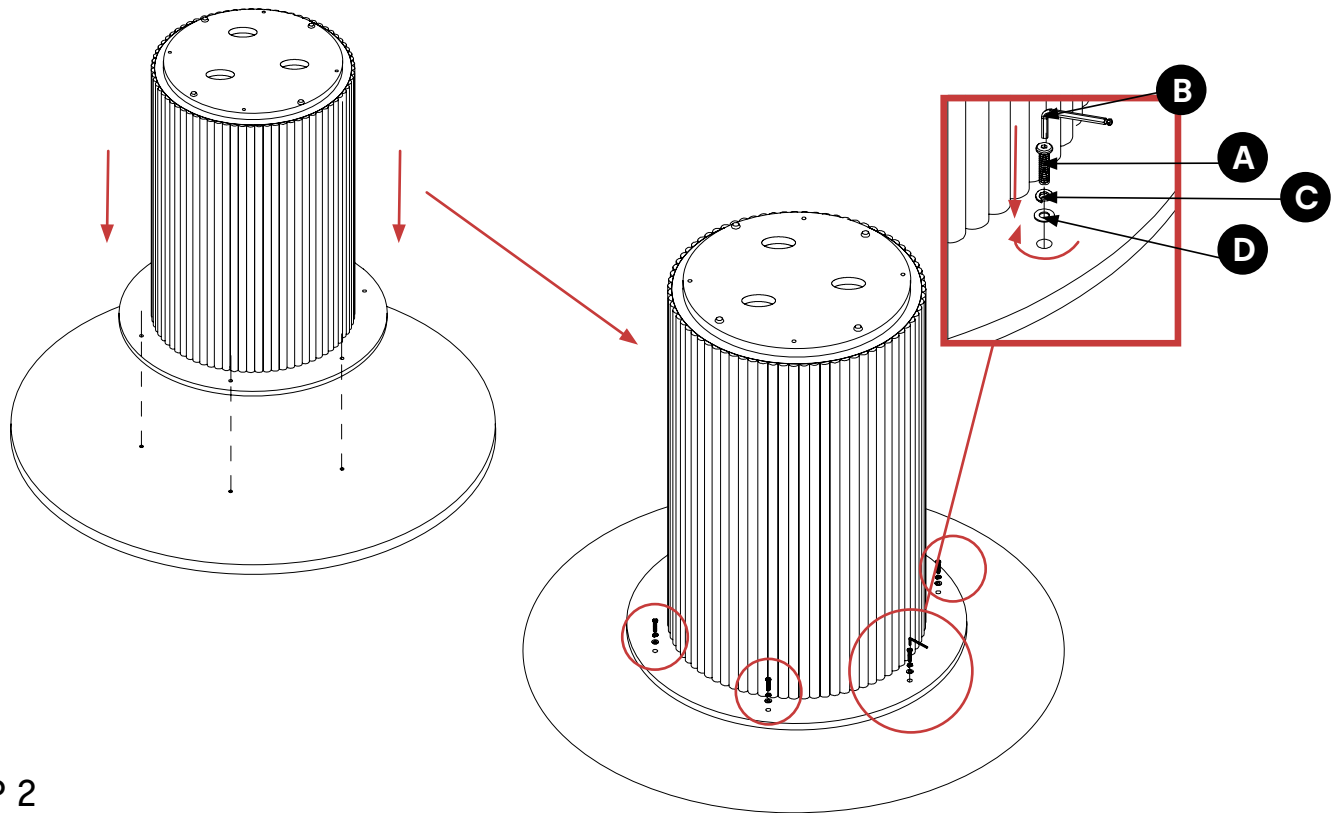

STEP 2

To make sure the table is level, you can adjust the feet on the bottom of the legs by rotating them higher or lower.

