

# Wexler Console Table

---





## ASSEMBLY INSTRUCTIONS

# JOON LOLOI

## ASSEMBLY INSTRUCTIONS: BEFORE BEGINNING

Read these instructions carefully and keep for future reference. Refer to parts inventory for guidance, and ensure you have all pieces before starting. When assembling, place all parts on a soft, clean, and flat surface such as a carpet to prevent scratches.

PARTS INVENTORY		
ID	DESCRIPTION	QTY
<b>1</b>	TOP	1
<b>2</b>	BASE	1

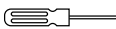
HARDWARE INVENTORY				
ID	IMAGE	DESCRIPTION	SIZE	QTY
<b>A</b>		ALLEN BOLT	M6 x 15mm	8
<b>B</b>		ALLEN WRENCH	M4 x 110mm	1
<b>C</b>		LOCK WASHER	—	8
<b>D</b>		SS WASHER	—	8
<b>E</b>		SCREWDRIVER	—	1

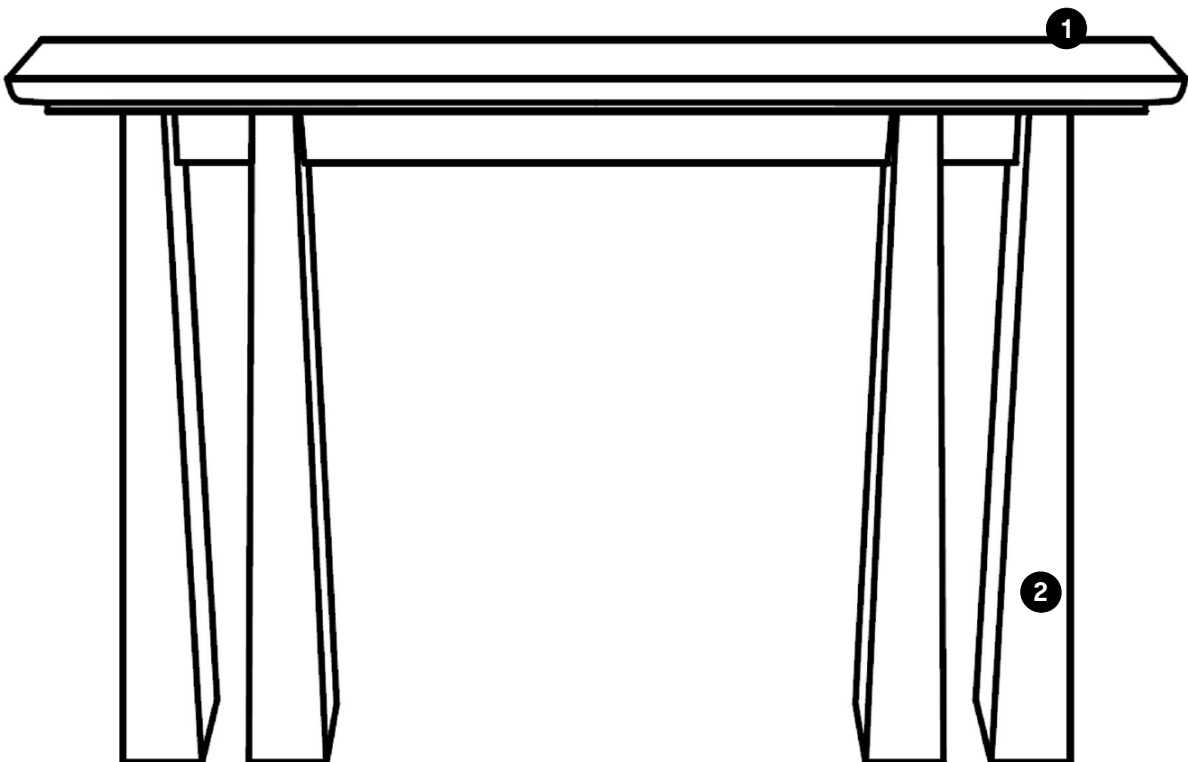

# JOON LOLOI

---

## STEP 1

Place **BASE (2)** upside down and unscrew the MDF plank with **SCREWDRIVER (E)**.

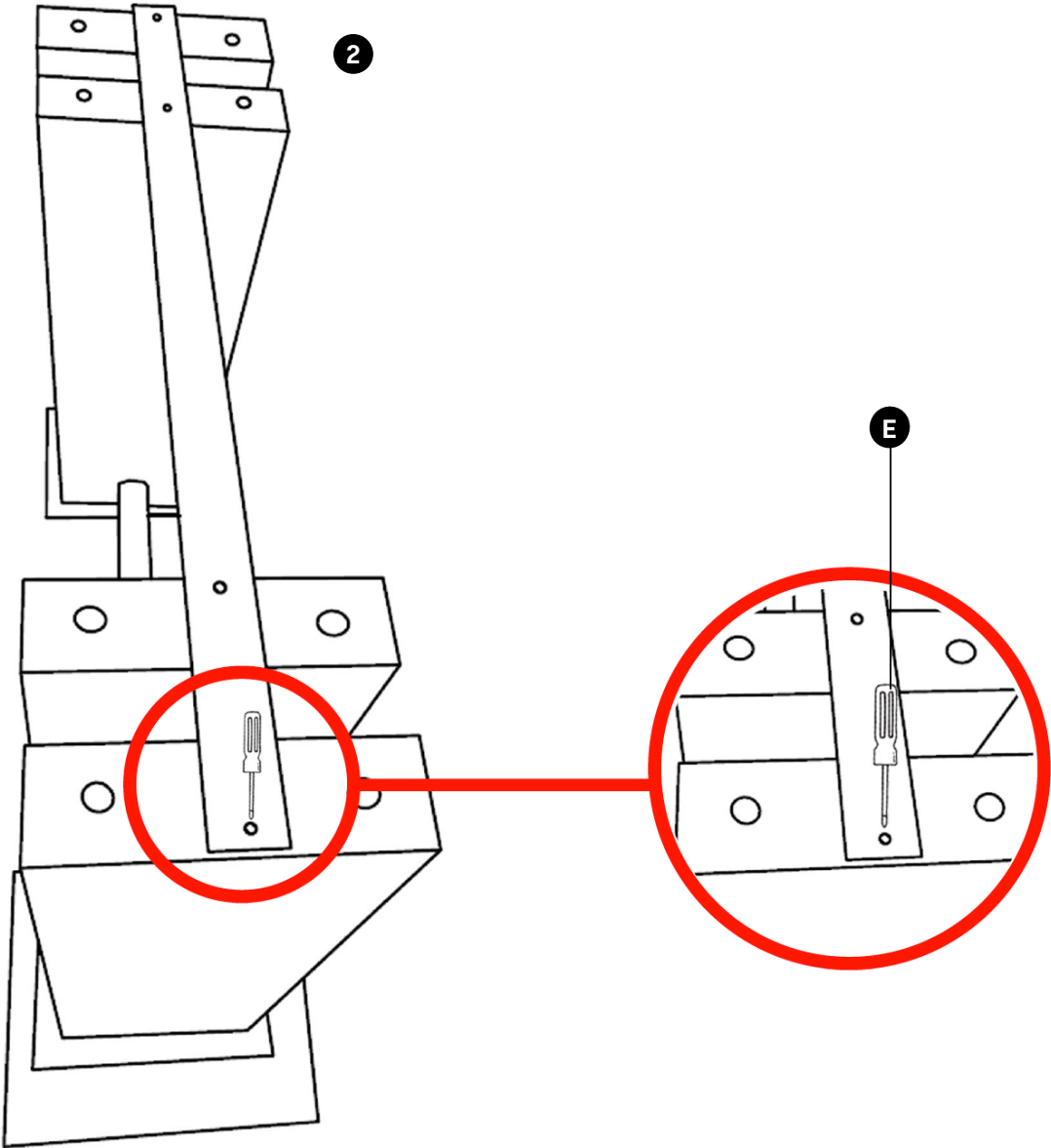

# JOON LOLOI

---

## STEP 2

Place **TOP (1)** upside down on a flat, smooth surface & align holes on **BASE (2)** with holes on **TOP (1)**.

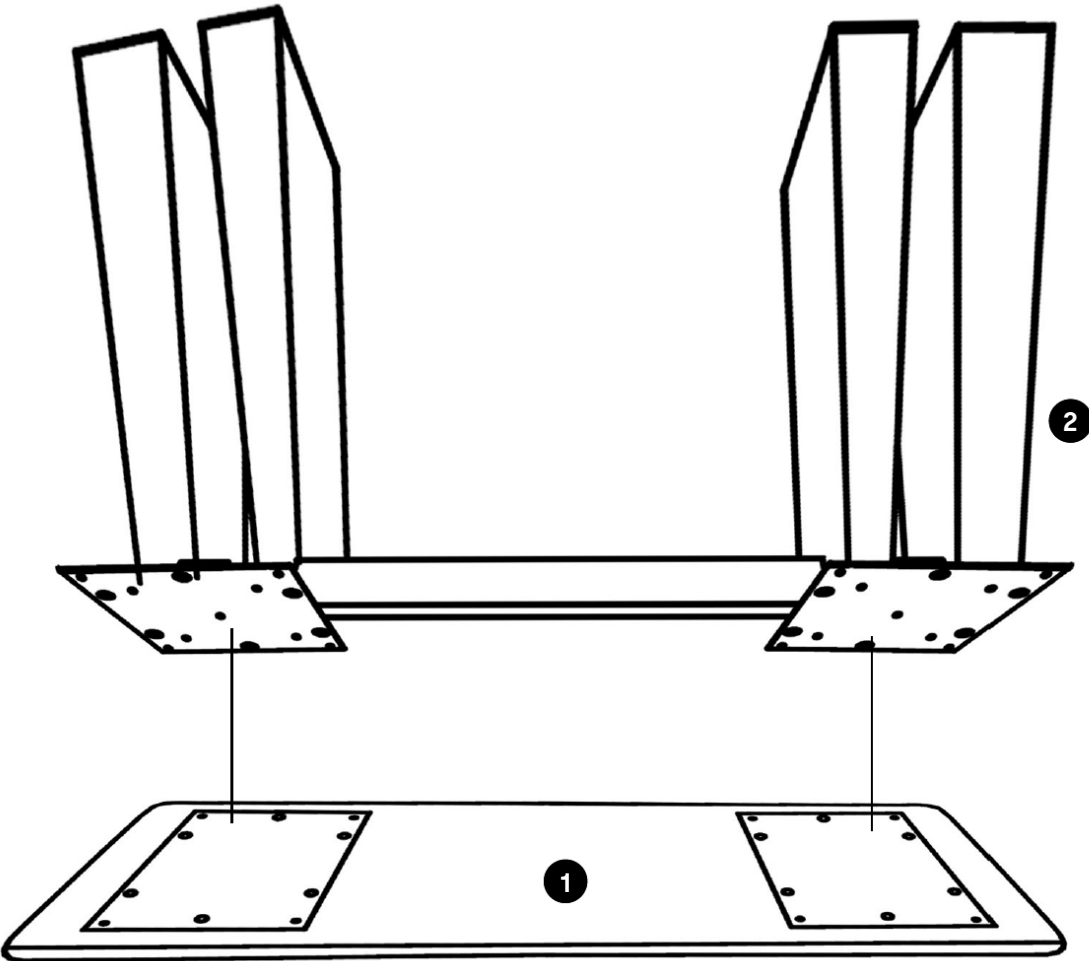

# JOON LOLOI

## STEP 3

Use 8 **ALLEN BOLTS (A)**, 8 **WASHERS (D)** & 8 **LOCK WASHERS (C)** to attach **TOP (1)** to **BASE (2)**. Use **ALLEN WRENCH (B)** to tighten bolts. Do not over tighten bolts.

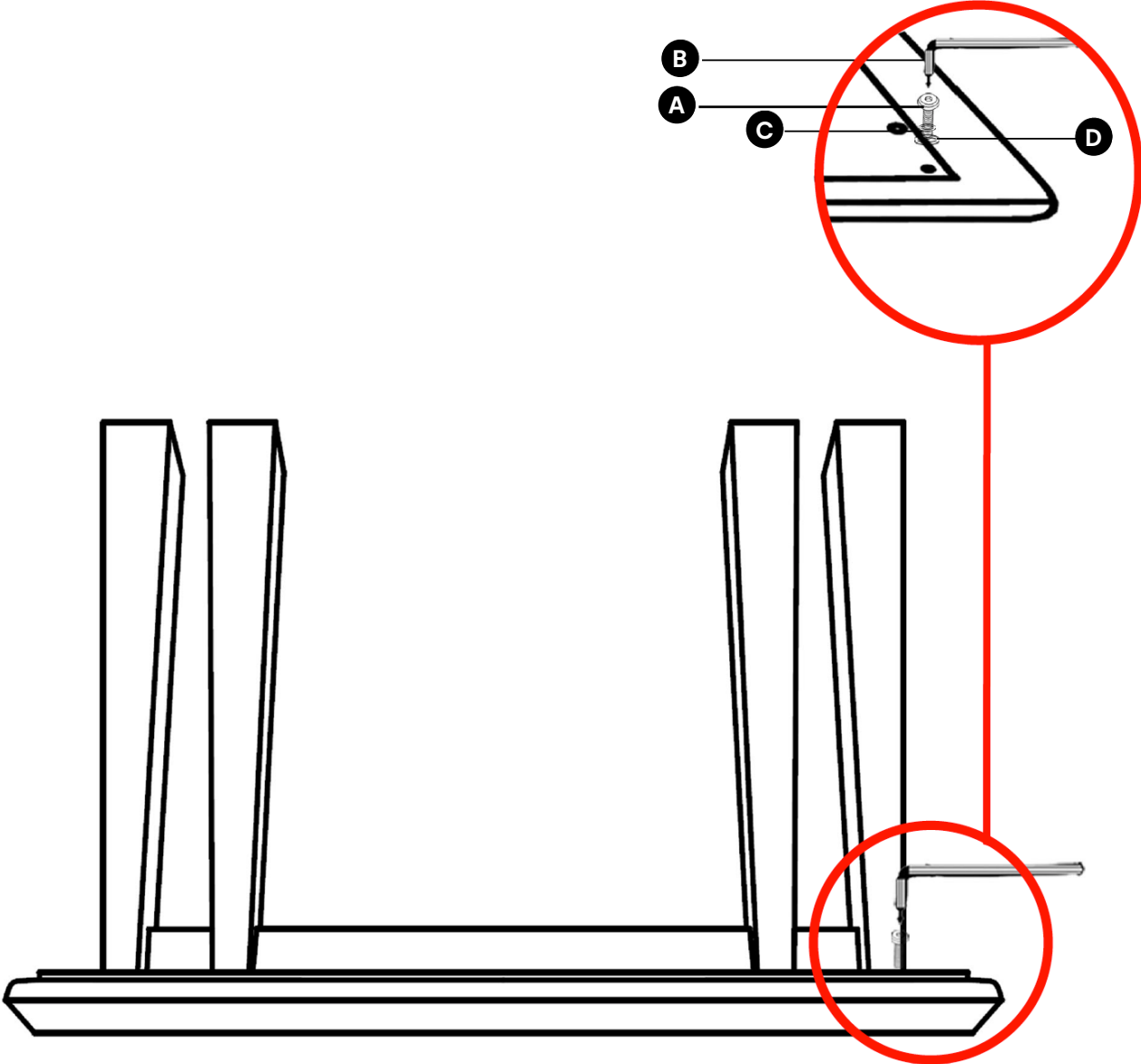

# JOON LOLOI

## NOTE

Levelers on bottom of legs can be adjusted if the floor is uneven.

