

Asymm Console Table

ASSEMBLY INSTRUCTIONS



JOON LOLOI

ASSEMBLY INSTRUCTIONS: BEFORE BEGINNING

Read these instructions carefully and keep for future reference. Refer to parts inventory for guidance, and ensure you have all pieces before starting. When assembling, place all parts on a soft, clean, and flat surface such as a carpet to prevent scratches.

1. Carefully unpack and position the item on a clean, non-marring surface to assemble.
2. Read these Assembly Instructions from beginning to end before starting to assemble.
3. Take an inventory of the required parts to ensure all are available.
4. To prevent accidental choking hazards, keep all packing materials away from small children.
5. Only tighten hardware until ALL hardware are fully engaged on their locations. Over-tighten bolts will damage the bolt threads.
6. Use only factory provided hardware to assemble. Unapproved hardware can damage product or jeopardize the structural integrity of the product.
7. The use of power tool to assemble is not recommended due to high risk of over-torque, which can damage the product.

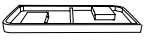
HARDWARE INVENTORY				
ID	IMAGE	DESCRIPTION	SIZE	QTY
A		ALLEN BOLT	40 x 8 mm	8
B		ALLEN WRENCH	5 mm	1
C		SPRING WASHER	15 x 8 mm	8
D		WASHER	20 x 8mm	8

FURNITURE INVENTORY			
ID	IMAGE	DESCRIPTION	QTY
E		TOP	1
F		BASE	2

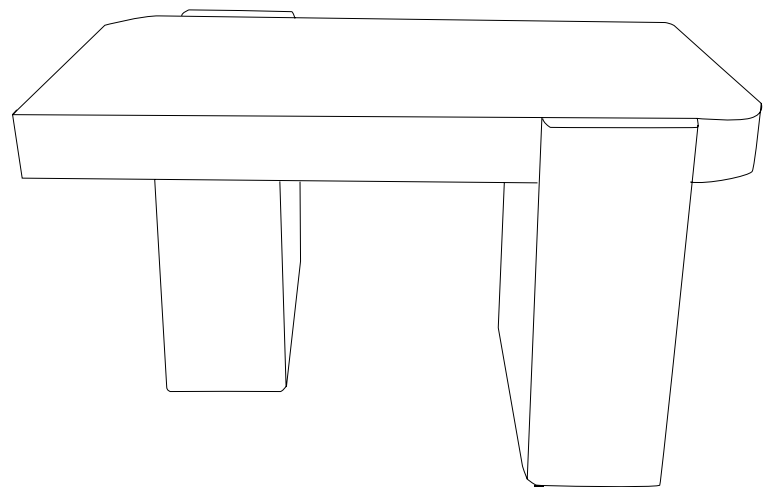

JOON LOLOI

STEP 1

Flip the TOP (E) over so the bottom is exposed and lay on a level clean surface. Place each BASE (F) on either end of the table placing them on top of the guide boxes. Make sure the holes are aligned on all sides of the BASE (F). Now thread the BOLTS (A) through each hole placing the SPRING WASHER (C) on first, followed by the WASHER (D). Then use the ALLEN WRENCH (B) to screw in each BOLT (A) set.

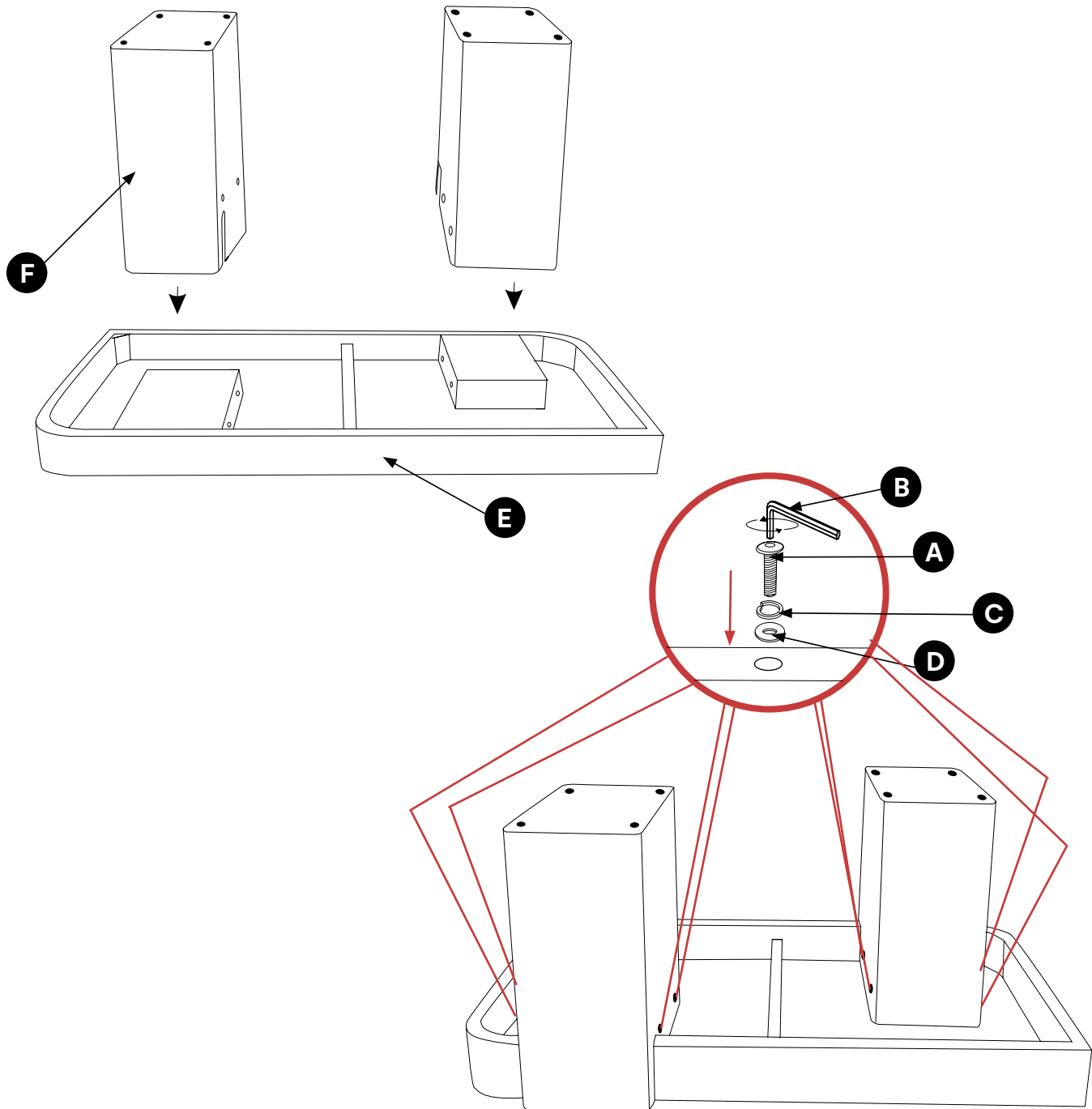

JOON LOLOI

STEP 2

Once both BASES (F) are secure, flip the table over. To make sure the table is level, you can adjust the feet on the bottom of the legs by rotating them higher or lower.

