

# Halsted Coffee Table

---

## ASSEMBLY INSTRUCTIONS





# JOON LOLOI

## ASSEMBLY INSTRUCTIONS: BEFORE BEGINNING

Read these instructions carefully and keep for future reference. Refer to parts inventory for guidance, and ensure you have all pieces before starting. When assembling, place all parts on a soft, clean, and flat surface such as a carpet to prevent scratches.

1. Carefully unpack and position the item on a clean, non-marring surface to assemble.
2. Read these Assembly Instructions from beginning to end before starting to assemble.
3. Take an inventory of the required parts to ensure all are available.
4. To prevent accidental choking hazards, keep all packing materials away from small children.
5. Only tighten hardware until ALL hardware are fully engaged on their locations. Over tighten bolts will damage the bolt threads.
6. Use only factory provided hardware to assemble. Unapproved hardware can damage product or jeopardize the structural integrity of the product.
7. The use of power tool to assemble is not recommended due to high risk of over-torque, which can damage the product.

PARTS INVENTORY		
ID	DESCRIPTION	QTY
<b>1</b>	TABLE TOP	1
<b>2</b>	TABLE LEGS	2
<b>3</b>	SUPPORTS TIE BAR	2

HARDWARE INVENTORY				
ID	IMAGE	DESCRIPTION	SIZE	QTY
<b>A</b>		ALLEN BOLT	M6 x 12mm	16
<b>B</b>		ALLEN BOLT	M6 x 45mm	4
<b>C</b>		FLAT WASHER	06 x 017mm	20
<b>D</b>		LOCK WASHER	06 x 013mm	20
<b>E</b>		ALLEN WRENCH/KEY	4mm	1

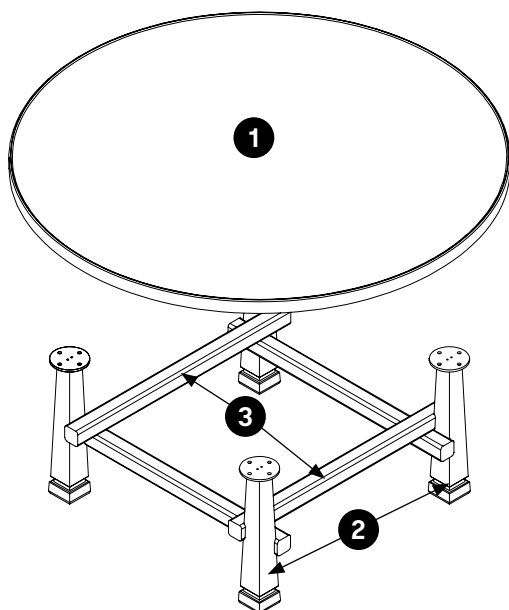

# JOON LOLOI

---

## STEP 1

Place **TABLE TOP (1)** on its back so that the bottom can be easily accessed. Slide the **LOCK WASHER (D)**, then the **FLAT WASHER (C)** onto the **ALLEN BOLT (A)**. Match up the bolt holes on the left **LEG (2)** and attach to the bottom of the table using the **ALLEN WRENCH (E)** to screw in the **ALLEN BOLT (A)**. Do this for all four **BOLTS (A)**.

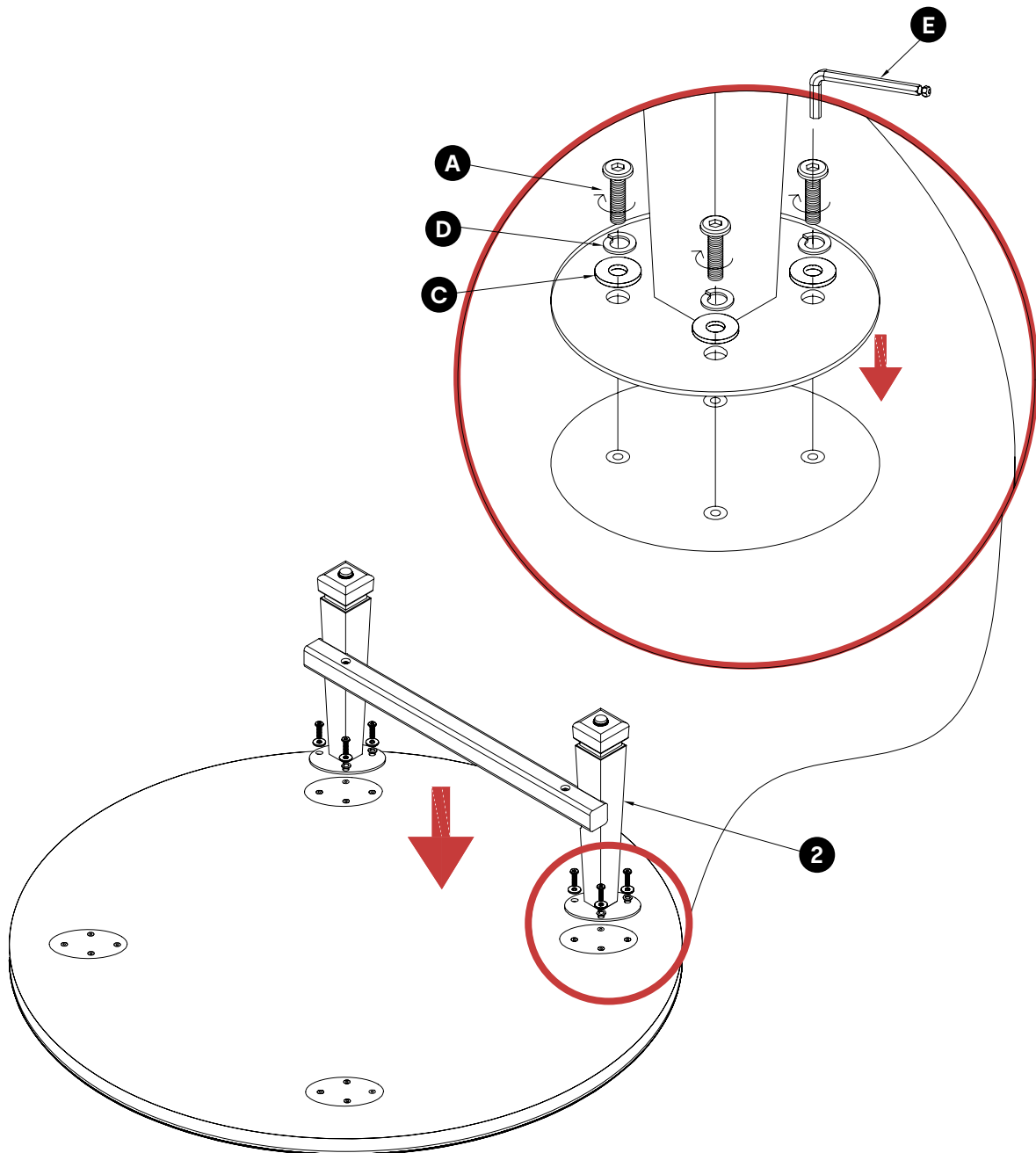

# JOON LOLOI

## STEP 2

Repeat **STEP 1** to attach the right **LEG (2)**. Slide the **LOCK WASHER (D)** and then the **FLAT WASHER (C)** onto the **ALLEN BOLT (A)**. Match up the bolt holes on the left leg and attach to the bottom of the **TABLE TOP (1)** using the **ALLEN WRENCH (E)** to screw in the **ALLEN BOLT (A)**. Do this for all four bolts.

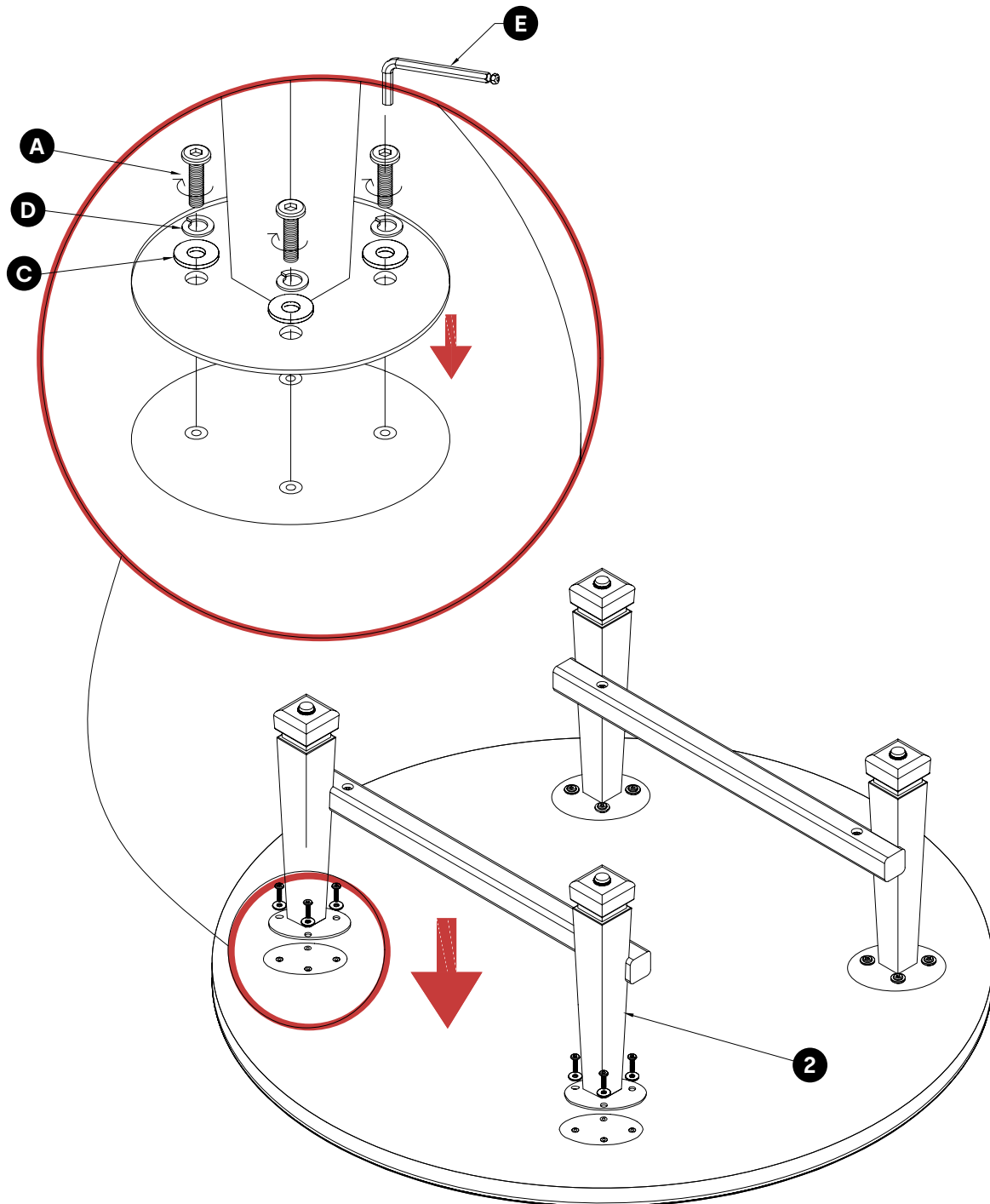

# JOON LOLOI

## STEP 3

Next, attach the two **SUPPORTS TIE BARS (3)**. Slide the **LOCK WASHER (D)** then the **FLAT WASHER (C)** onto the **ALLEN BOLT (B)**. Match up the bolt holes on the left and right **LEG (2)** attach to the bottom of the **SUPPORTS TIE BAR (3)** using the **ALLEN WRENCH (E)** to screw in the **ALLEN BOLTS (B)**. Do this to all four bolts.

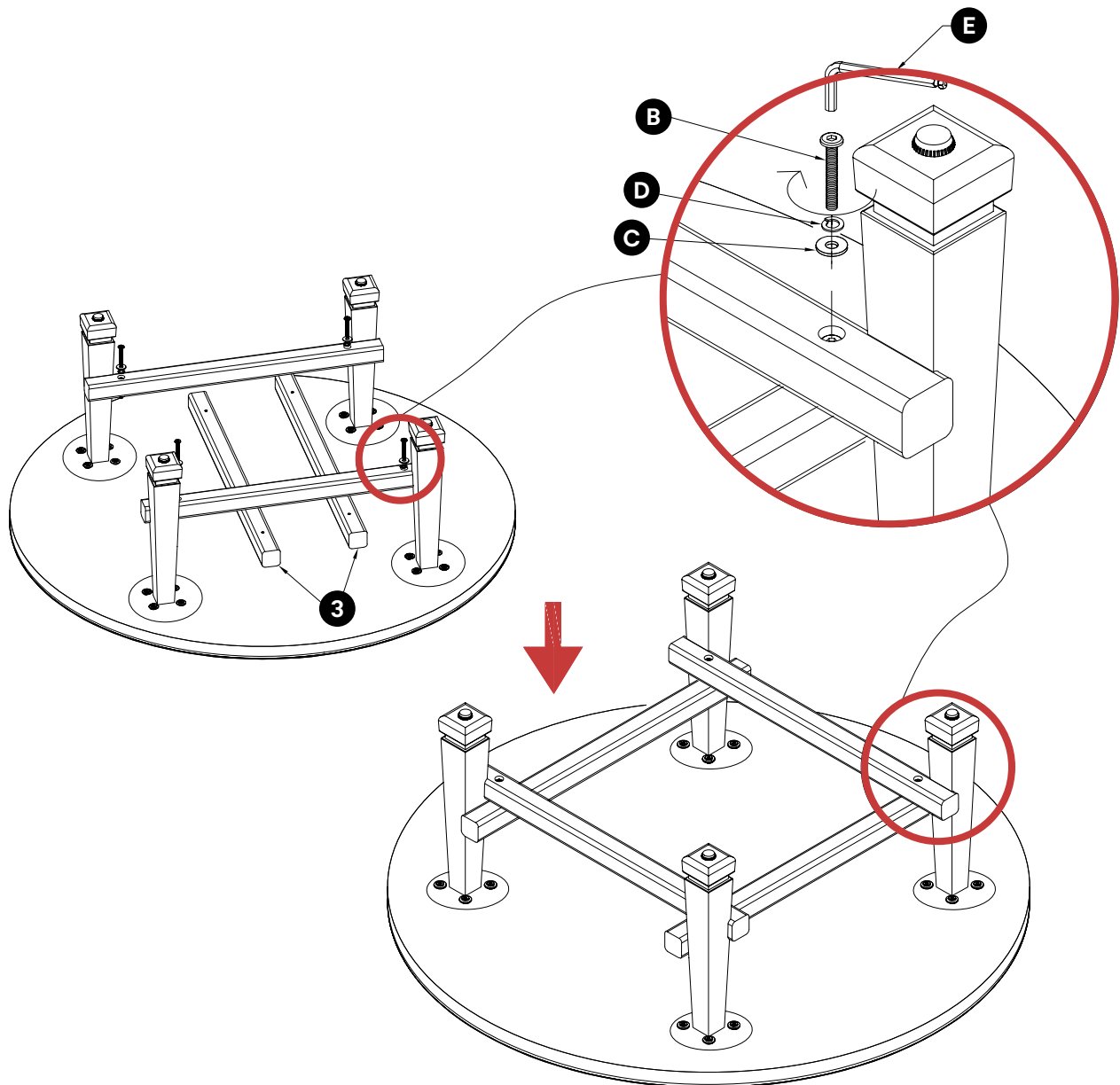

# JOON LOLOI

---

## STEP 4

All four LEGS (2) on teh Halsted Coffee Table have the ability to move up and down by twisting to the left or right. This allows the user to make the table level. Adjust levelers as needed.

